

**51 GSM SQUARE TO ROUND FITTING**  
NO SCALE

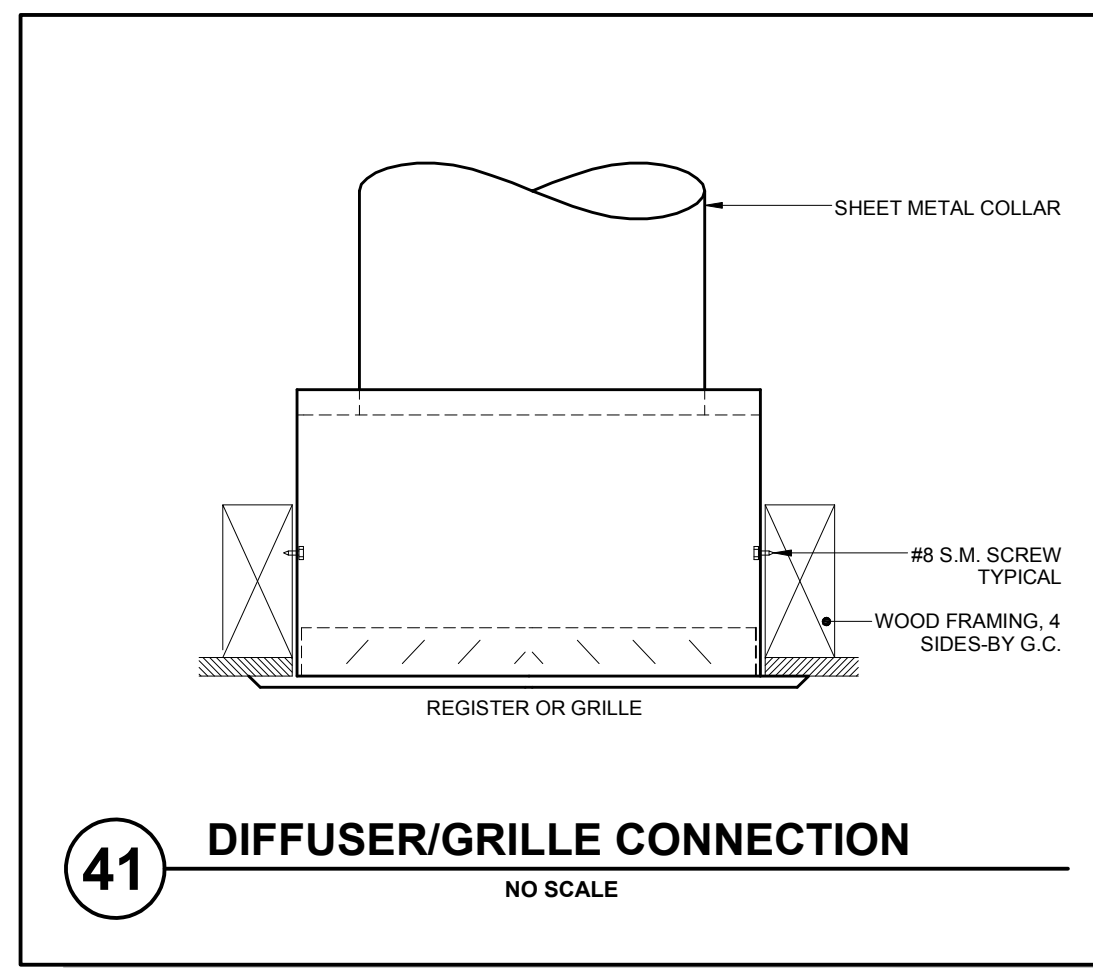

**41 DIFFUSER/GRILLE CONNECTION**  
NO SCALE

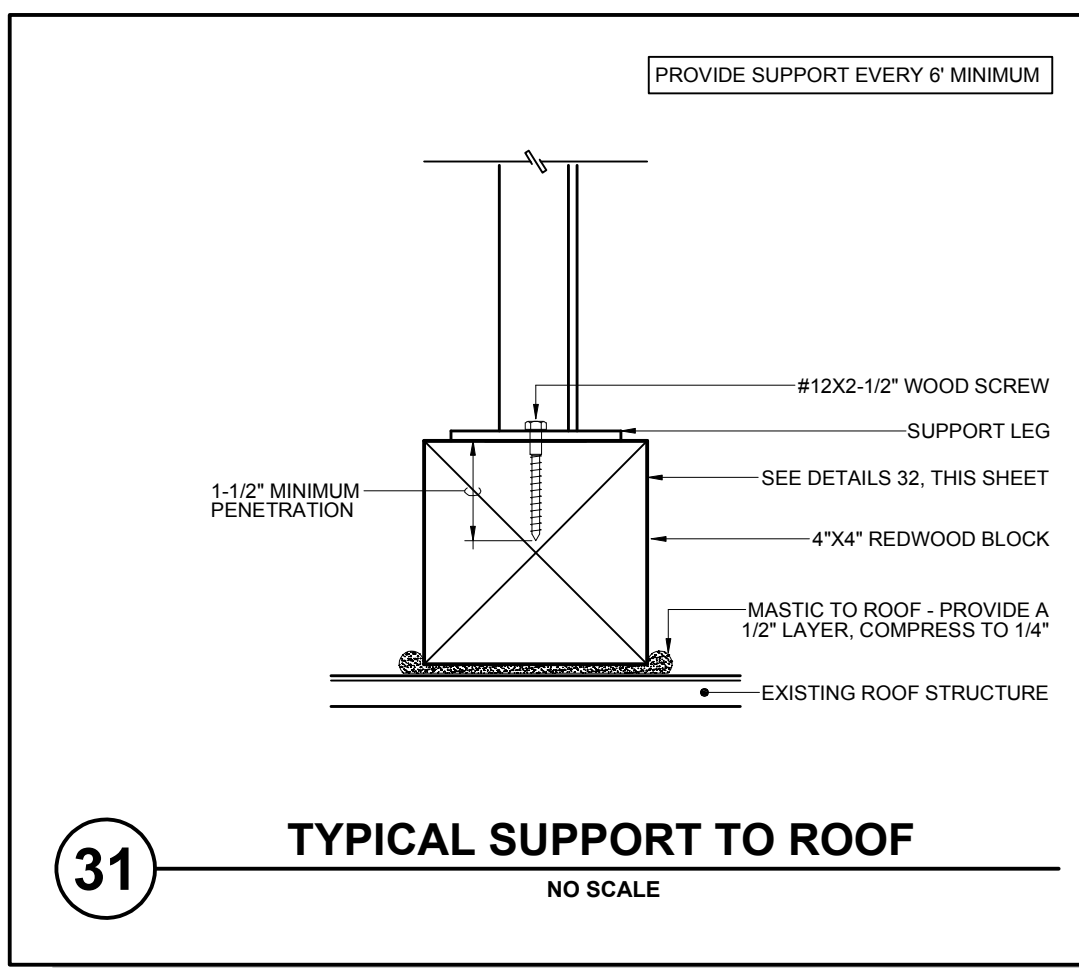

**31 TYPICAL SUPPORT TO ROOF**  
NO SCALE

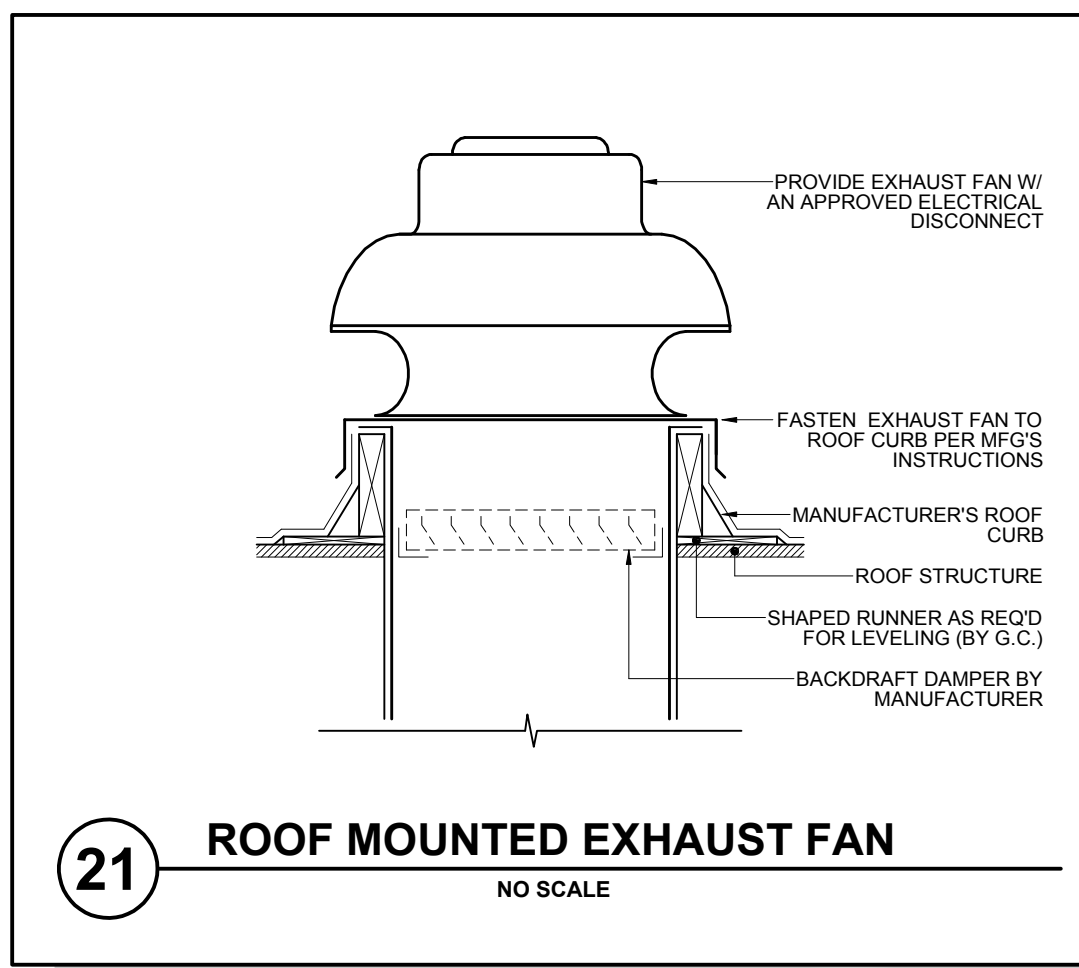

**21 ROOF MOUNTED EXHAUST FAN**  
NO SCALE

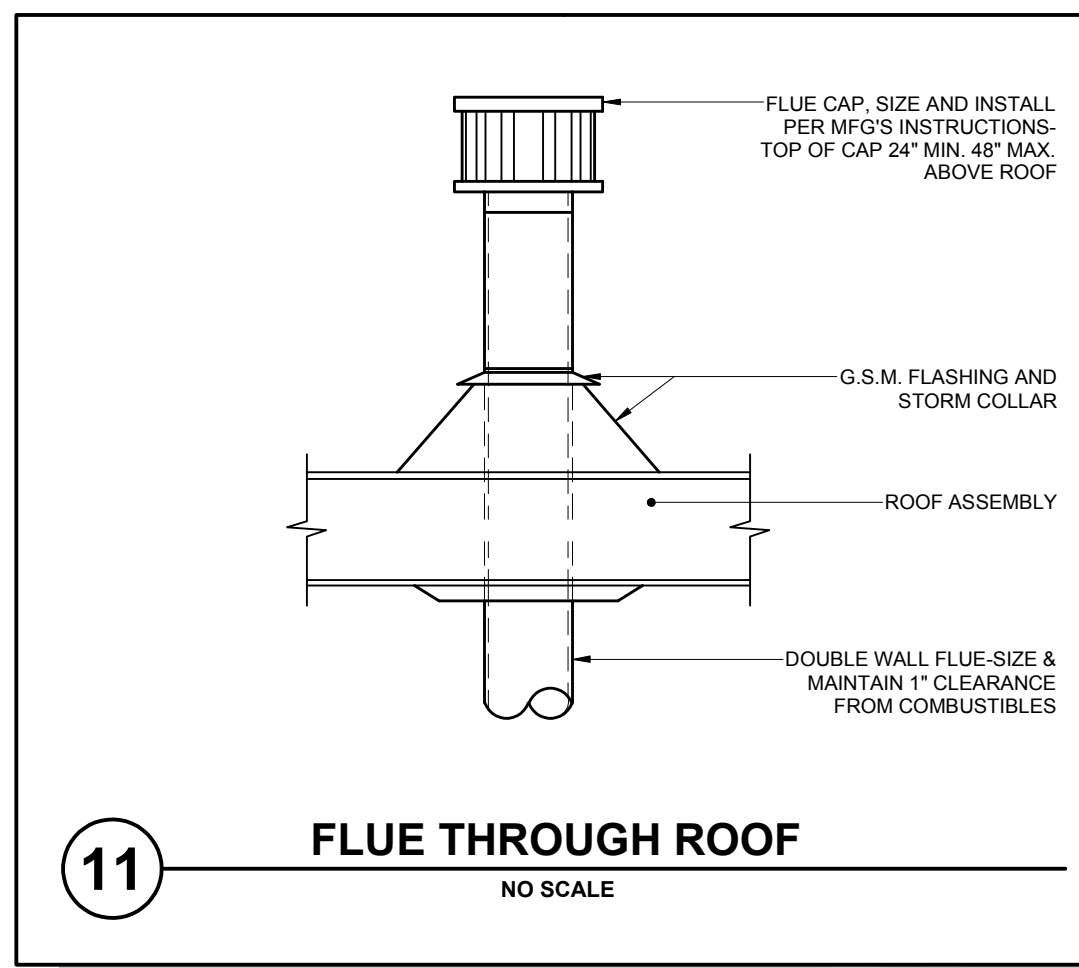

**11 FLUE THROUGH ROOF**  
NO SCALE

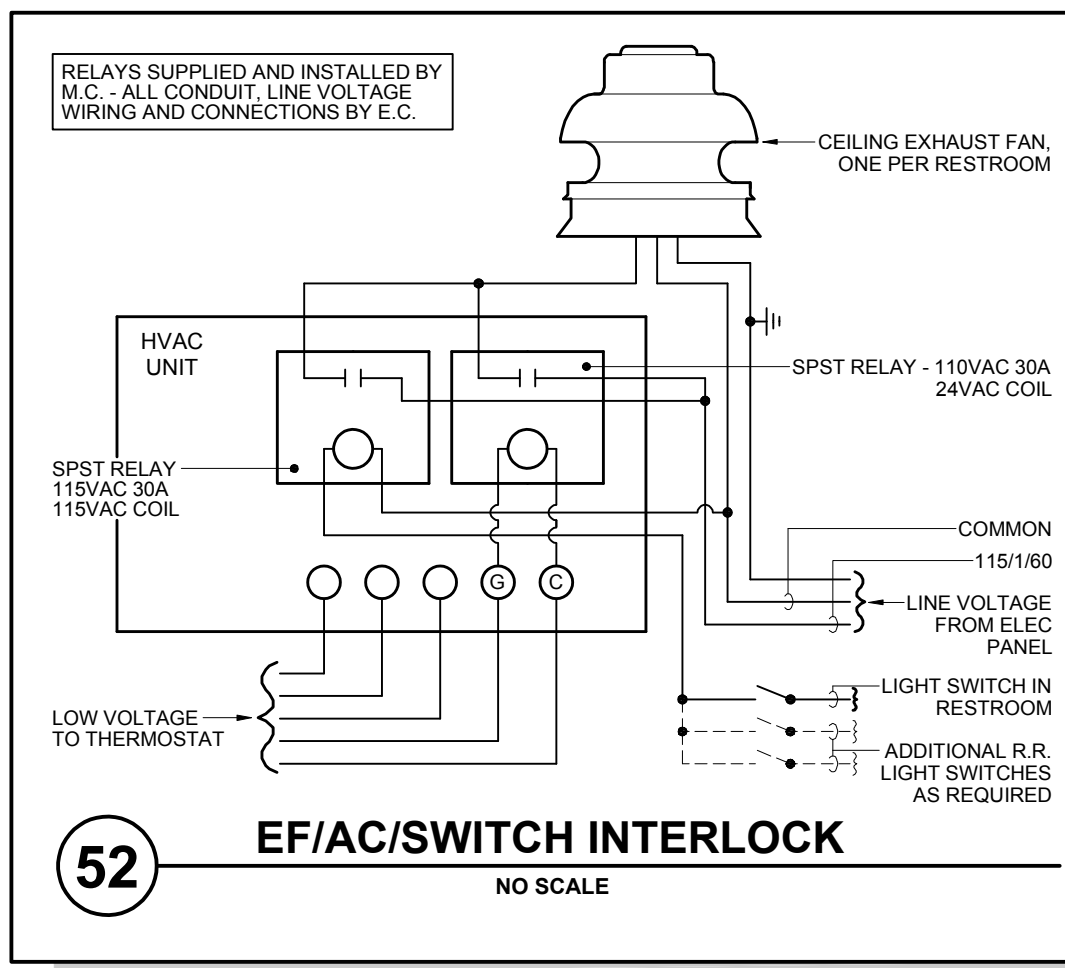

**52 EF/AC/SWITCH INTERLOCK**  
NO SCALE

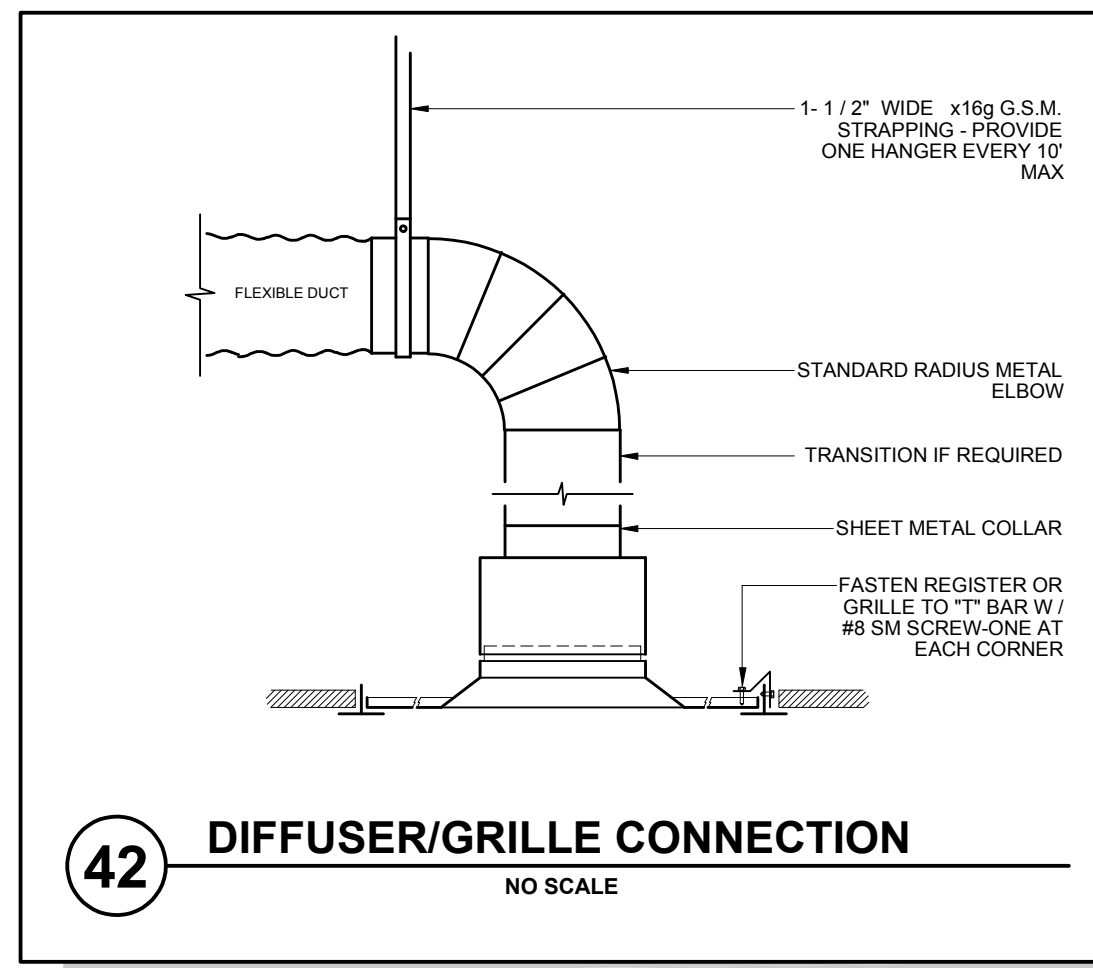

**42 DIFFUSER/GRILLE CONNECTION**  
NO SCALE

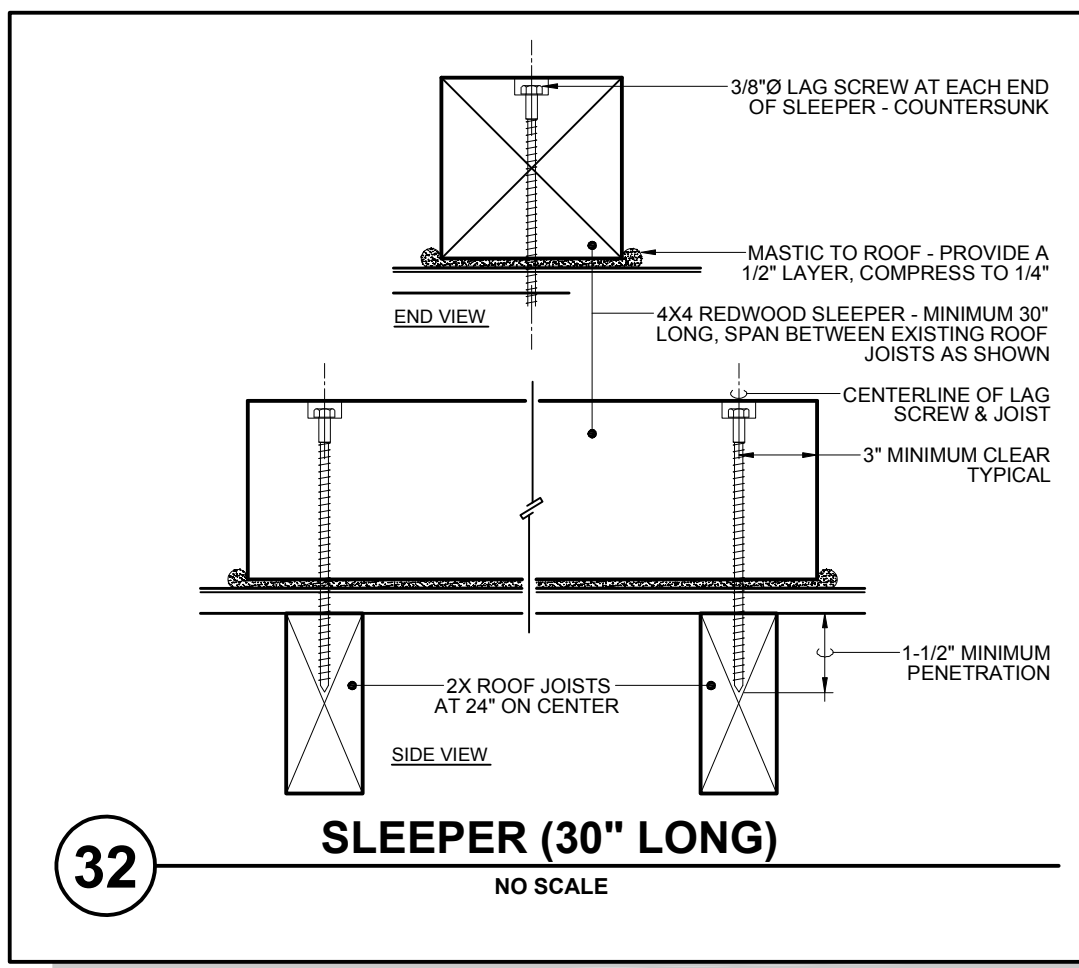

**32 SLEEPER (30\"/>**

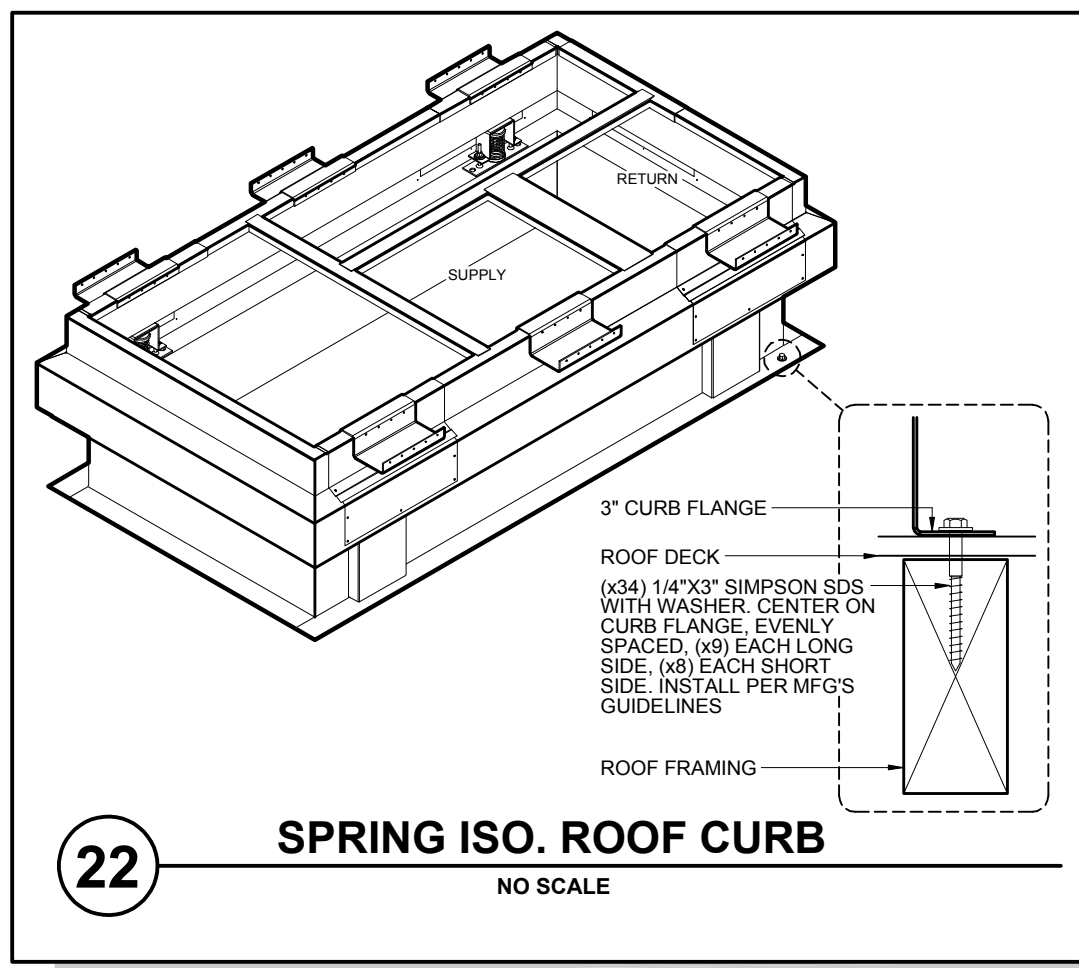

**22 SPRING ISO. ROOF CURB**  
NO SCALE

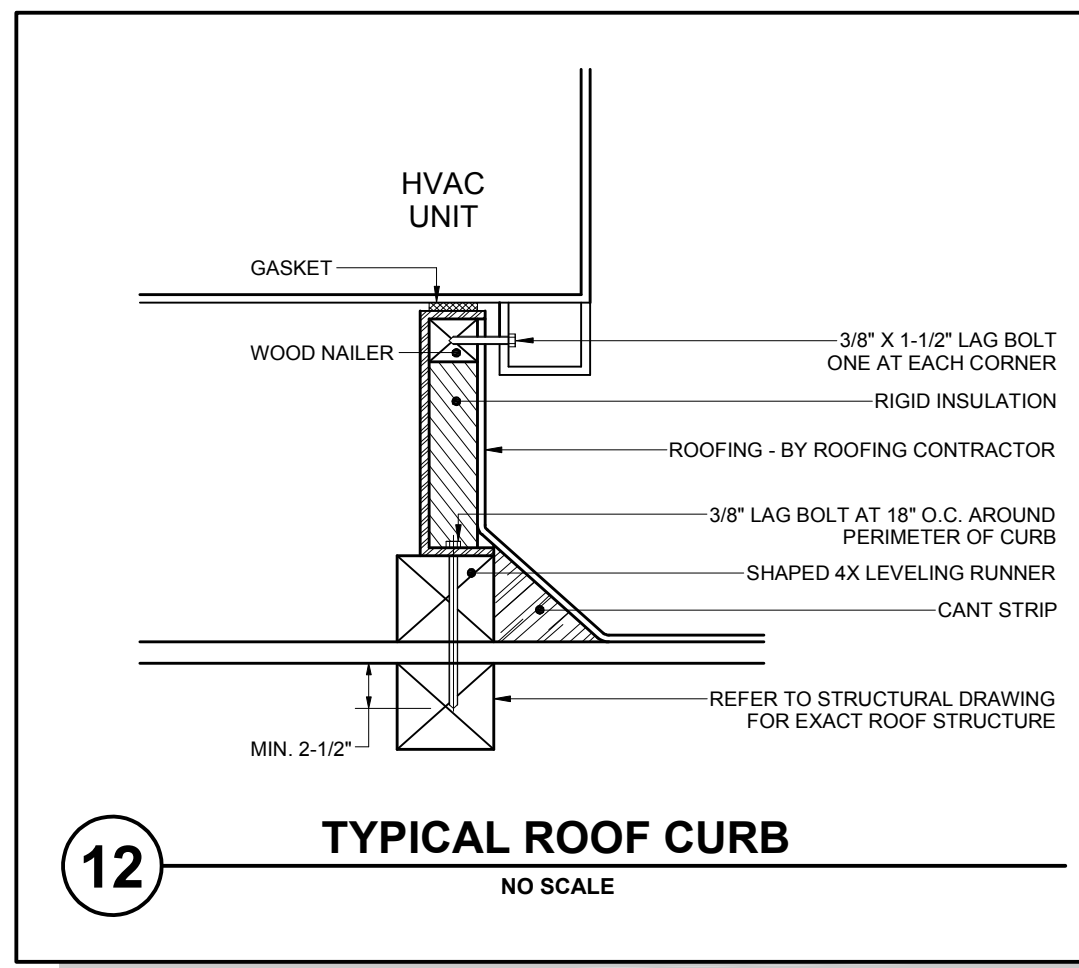

**12 TYPICAL ROOF CURB**  
NO SCALE

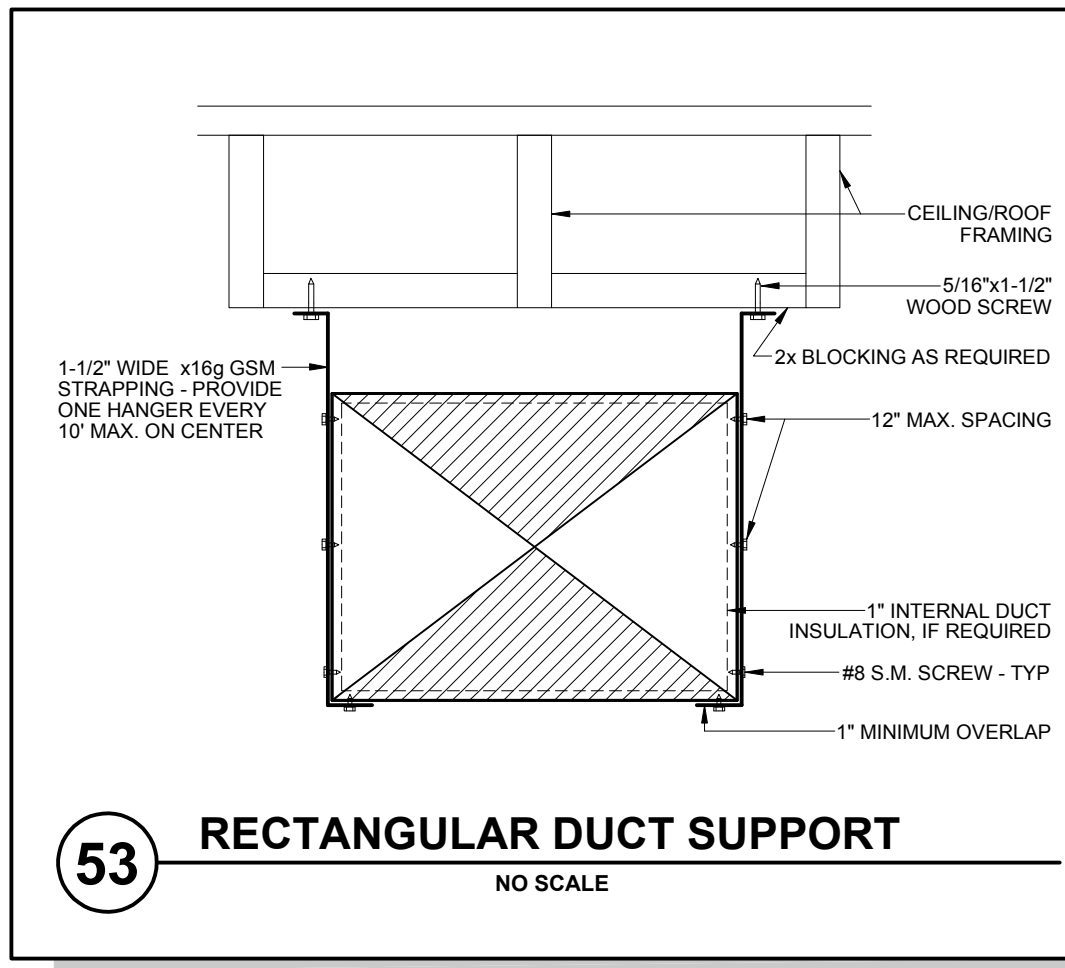

**53 RECTANGULAR DUCT SUPPORT**  
NO SCALE

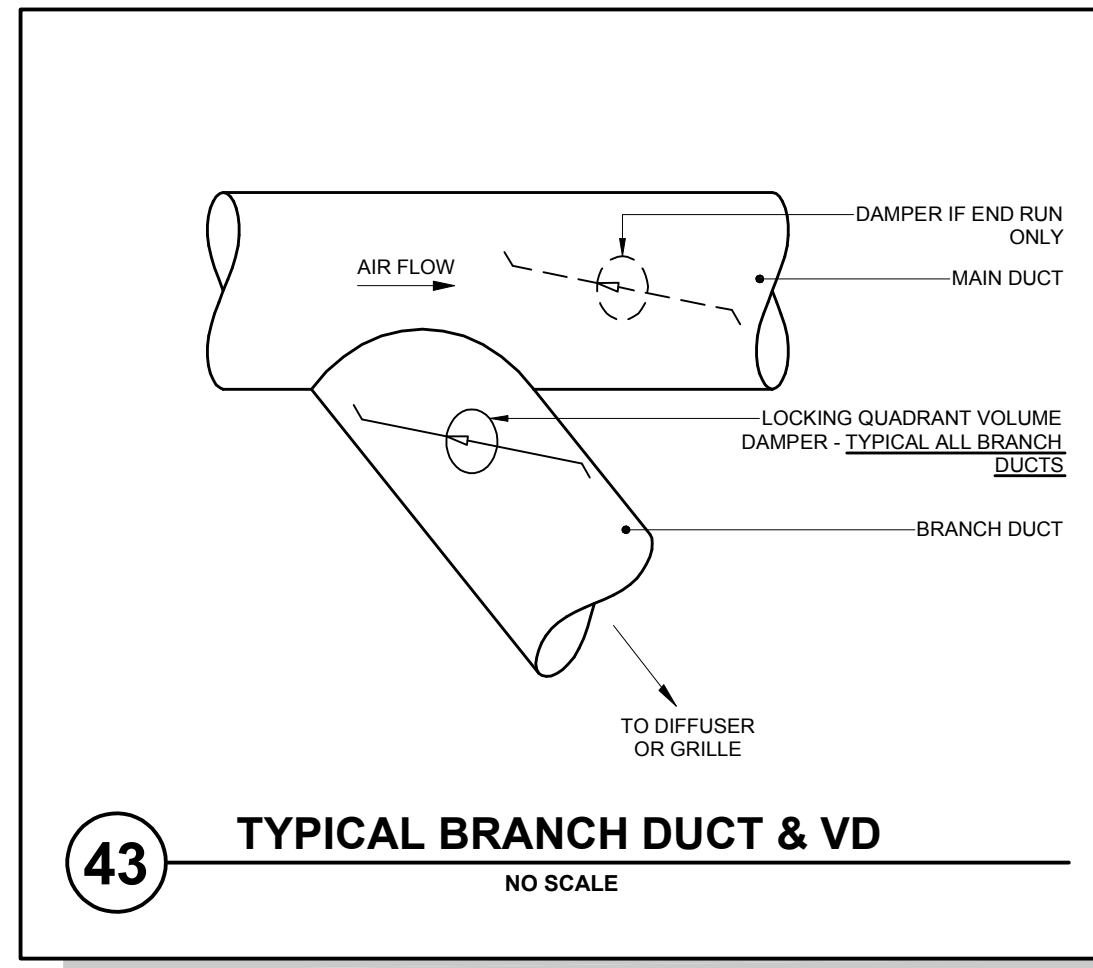

**43 TYPICAL BRANCH DUCT & VD**  
NO SCALE

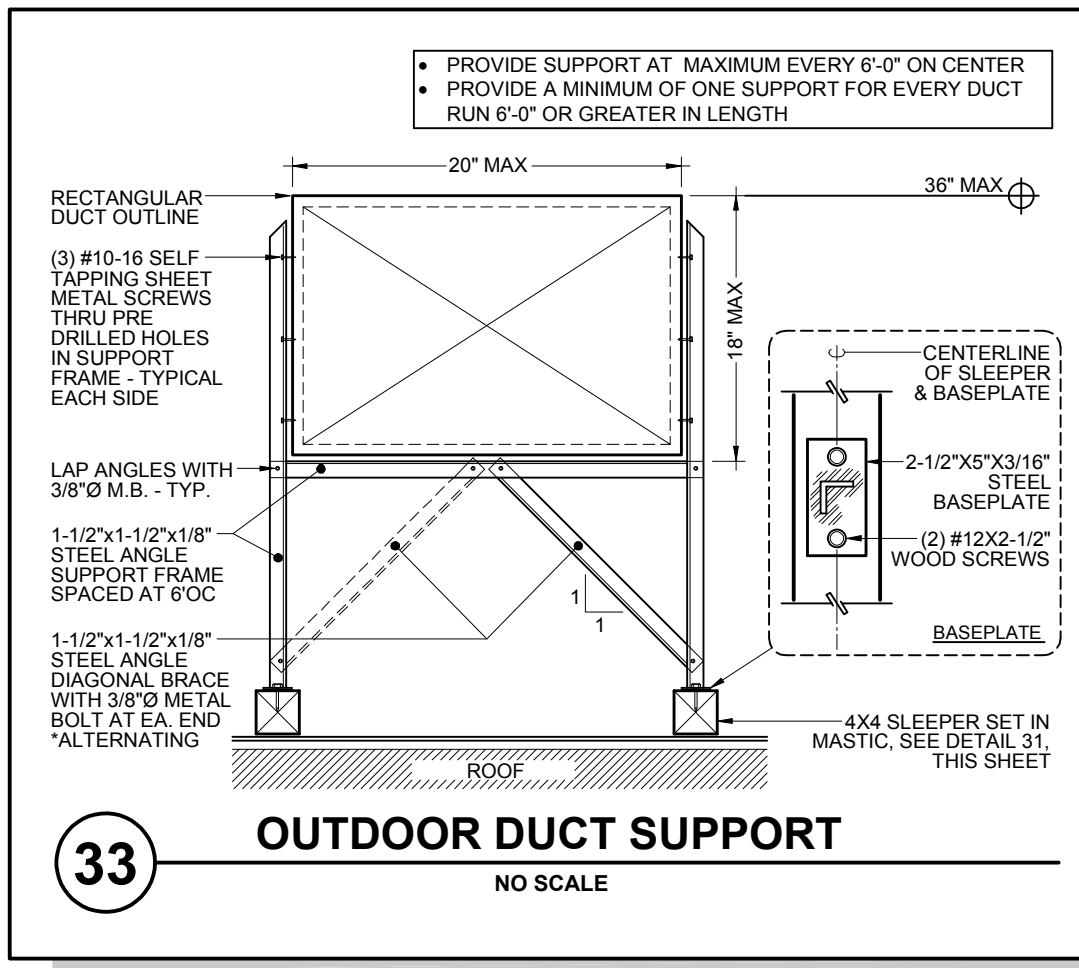

**33 OUTDOOR DUCT SUPPORT**  
NO SCALE

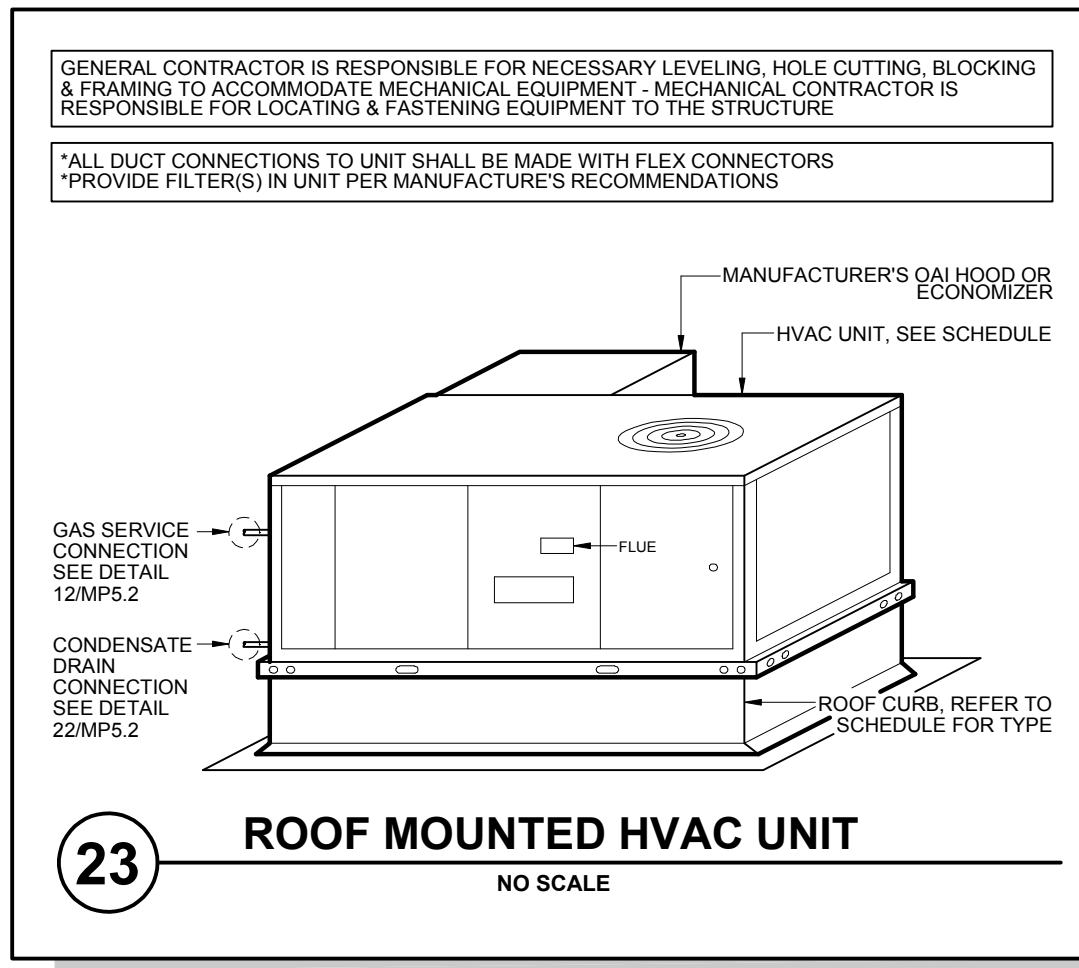

**23 ROOF MOUNTED HVAC UNIT**  
NO SCALE

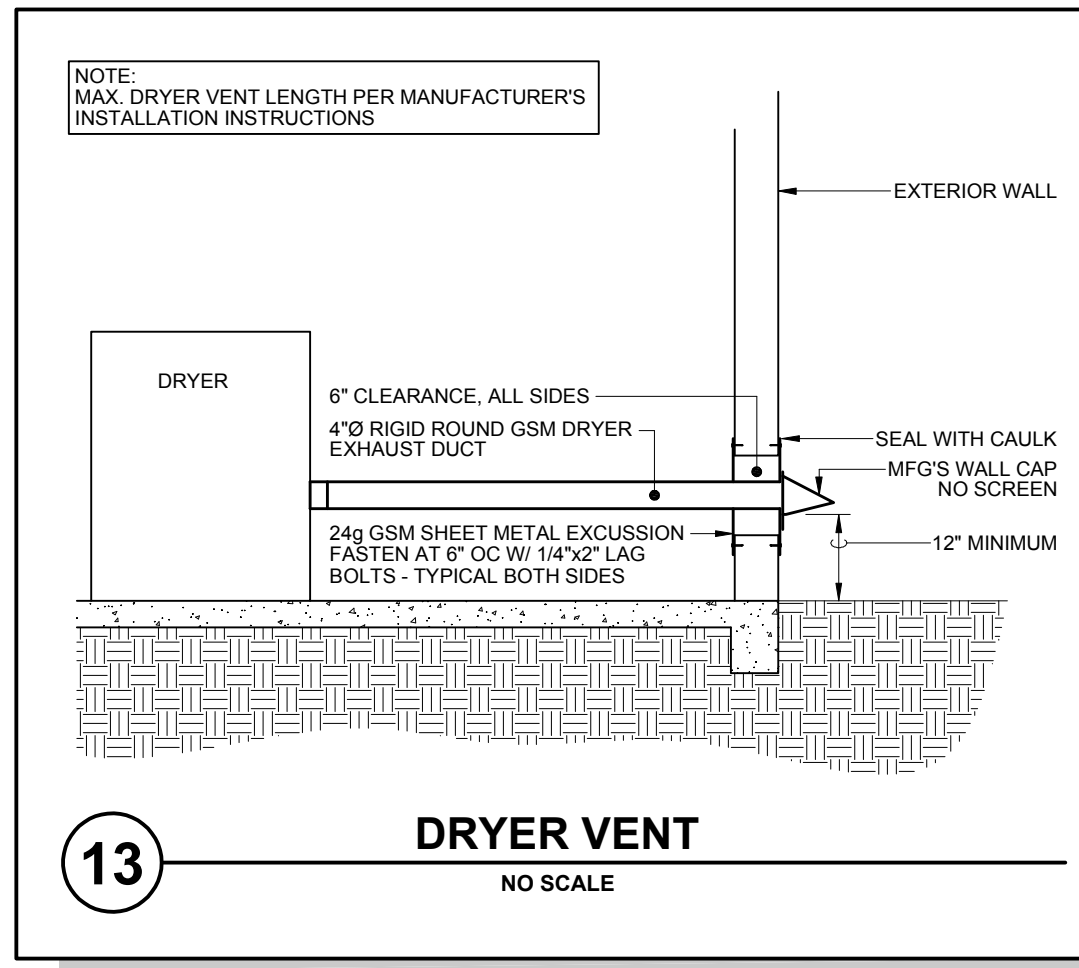

**13 DRYER VENT**  
NO SCALE

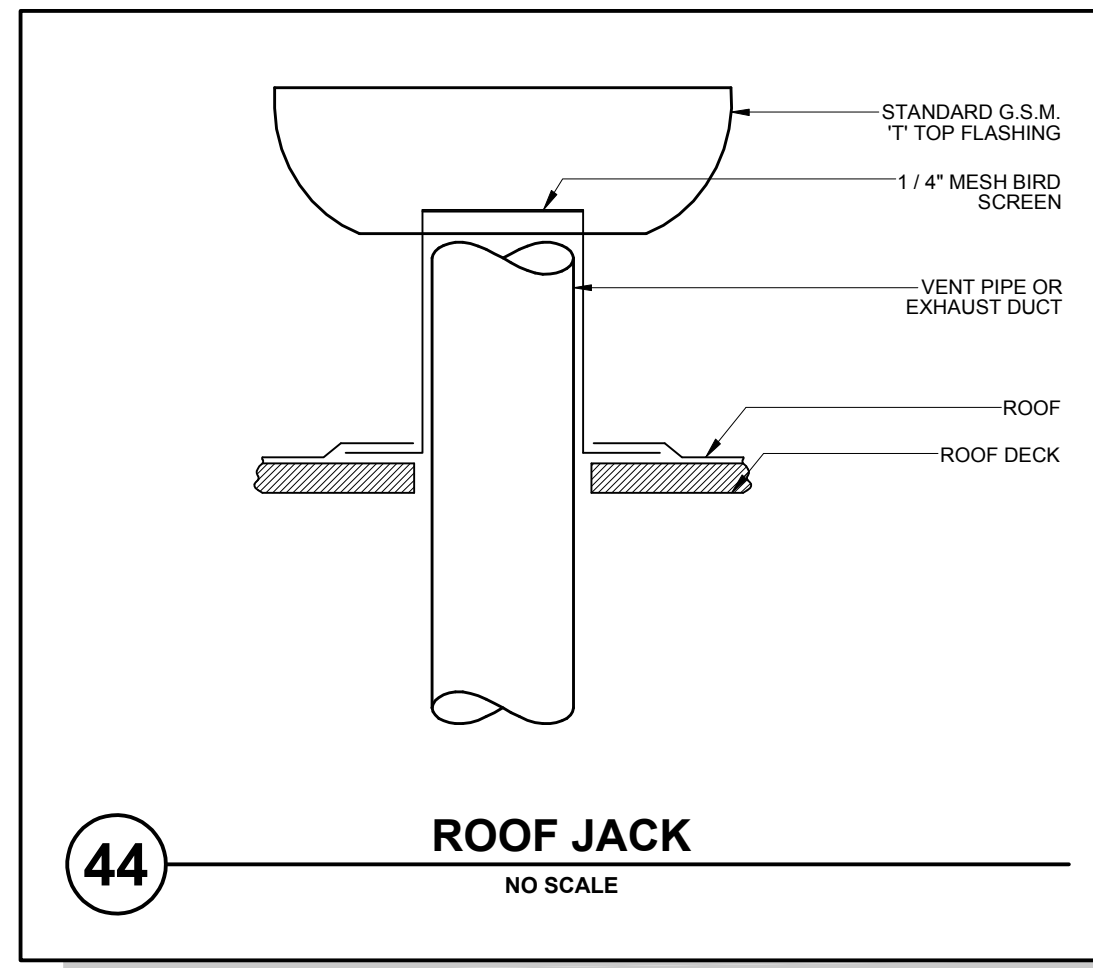

**44 ROOF JACK**  
NO SCALE

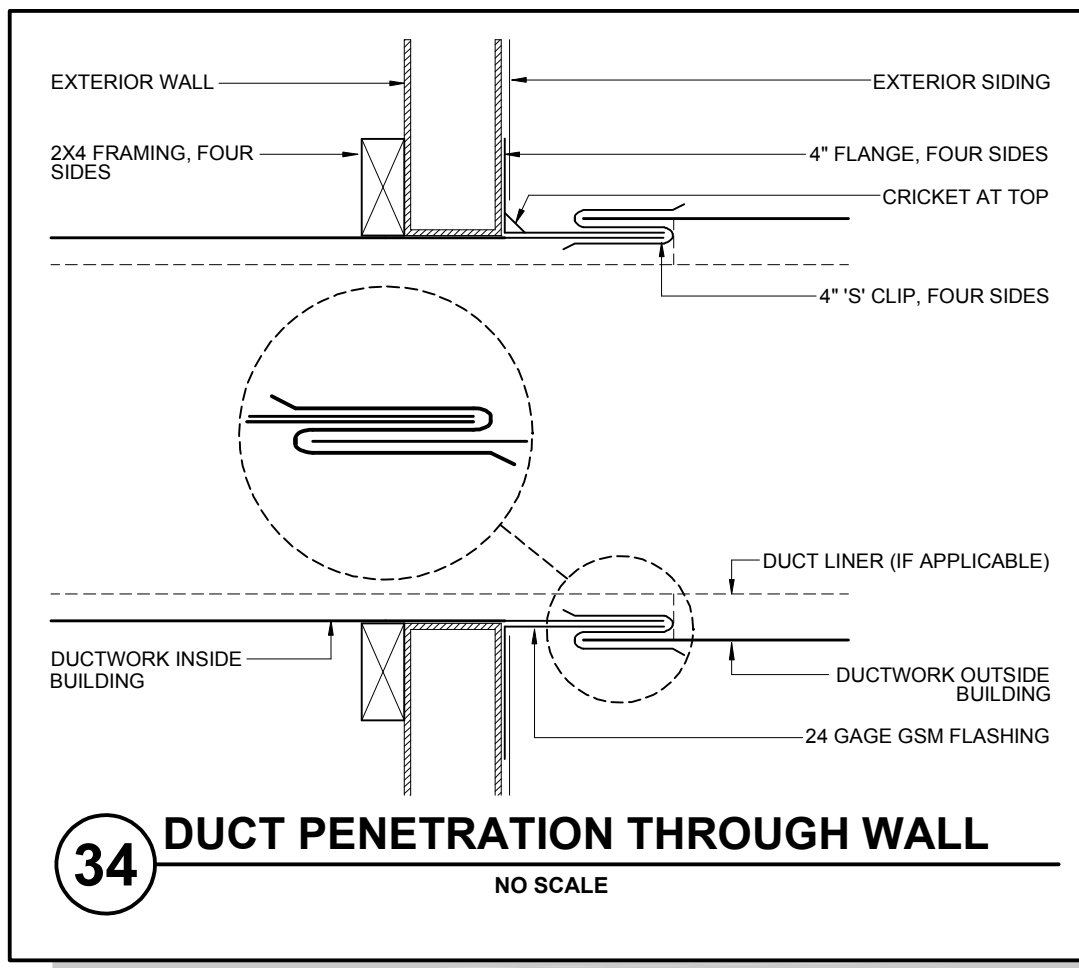

**34 DUCT PENETRATION THROUGH WALL**  
NO SCALE

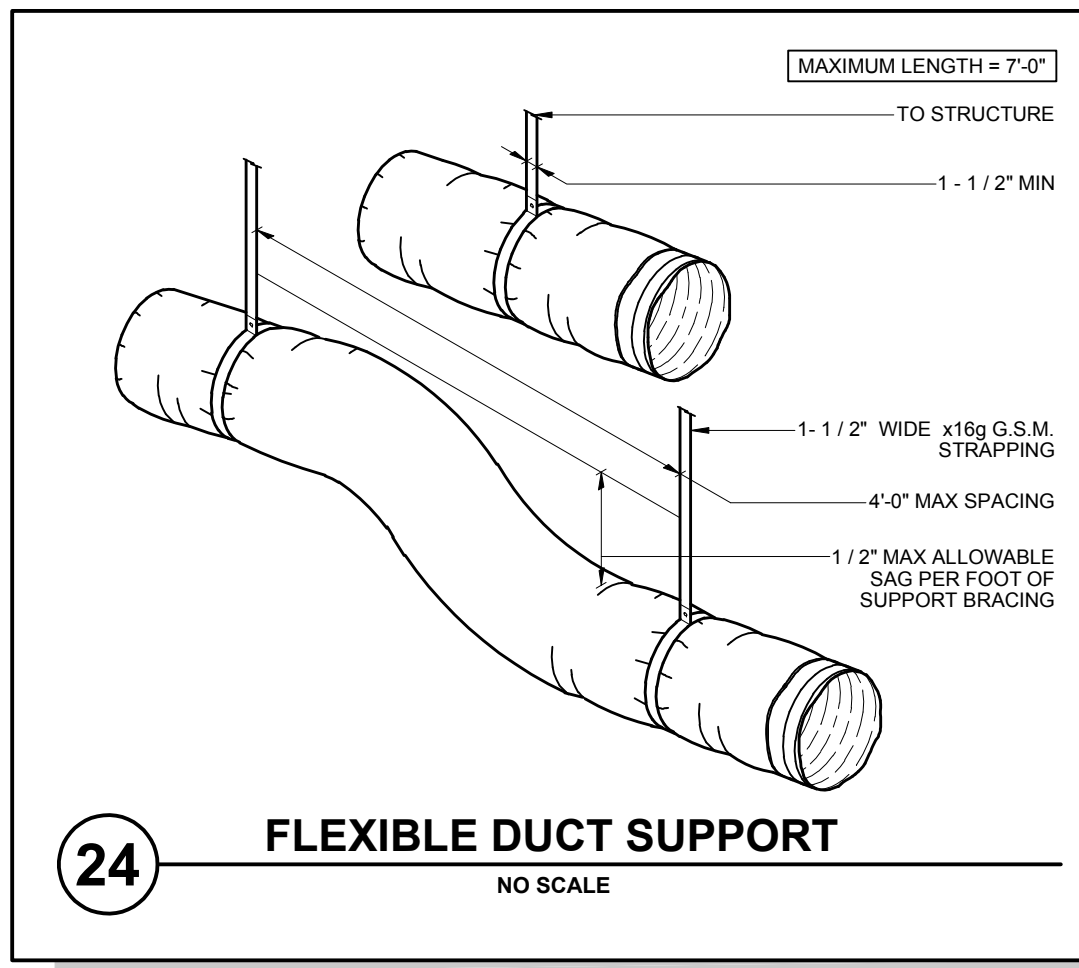

**24 FLEXIBLE DUCT SUPPORT**  
NO SCALE

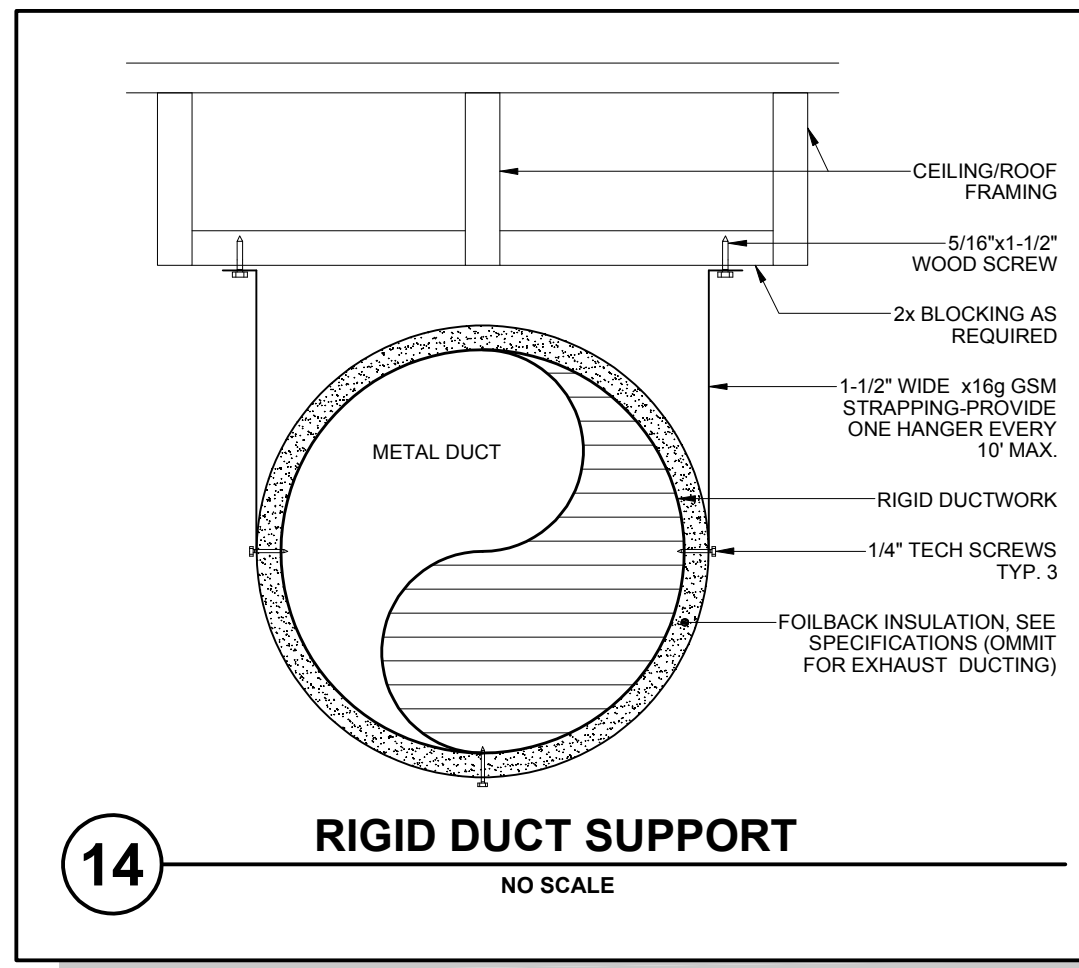

**14 RIGID DUCT SUPPORT**  
NO SCALE



**JVA MECHANICAL ENGINEERING**  
1023 NIPOND STREET, SUITE 200, SAN LUIS OBISPO, CA 94901  
T: (805) 543-3190 F: (805) 543-1168 E: JIM@JVA-MECH.COM  
JAMES L. VAN DE VANTER, P.E. & ASSOCIATES

---

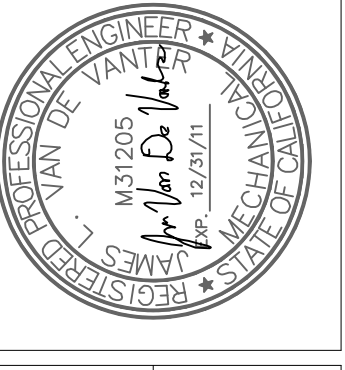

Professional Engineer  
JAMES L. VAN DE VANTER  
No. 12727  
Mechanical Engineering  
State of California

---

PROJECT TITLE:  
**NEW COMMON BUILDING**  
ROLLING HILLS APARTMENTS  
TEMPLETON, CA

CLIENT:  
**FRASER SEIPLE ARCHITECTS**  
8771 LOS ROBLES STREET  
SAN LUIS OBISPO, CA  
(805) 544-6161

---

SHEET TITLE AND DESCRIPTION:  
**DETAILS**

---

DATE	REMARKS
04.15.2010	DESIGN DEVELOPMENT
05.17.2010	FIRST SUBMITTAL
08.18.2010	PLAN CHECK 1

---

PLOT DATE:  
**8/16/2010 8:00 AM**

DRAWN BY:  
**TDR**

JVA JOB #  
**M10024**

---

SHEET  
DETAILS  
**MP5.1**